

## WALL MOUNTED AXIAL PROPELLER



### FEATURES

- 315mm to 1250mm diameter.
- Volume flow from 0.4m<sup>3</sup>/s to 35m<sup>3</sup>/s.
- Static pressure up to 400 Pa.
- Mild steel construction with a high quality epoxy powder coating or hot dip galvanised.
- Impellers have GRP blades or die-cast aluminum adjustable blades.
- IEC standard or smoke extract motors, single or two speed; with protection guard as an option.

### ORDERING CODE

WPA 630 - 20° - 4

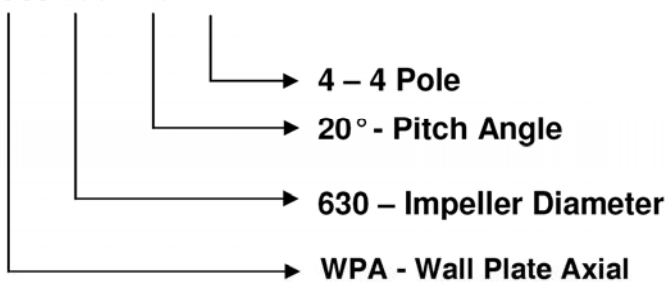

### MOTOR

Totally enclosed squirrel cage induction motor specially designed for minimum power consumption to cater for the desired fan characteristic. Motor are provided with following features :

- Class F insulation (Class H – optional).
- Electricity Supply : Single / Three Phase.
- IP 55 protection.

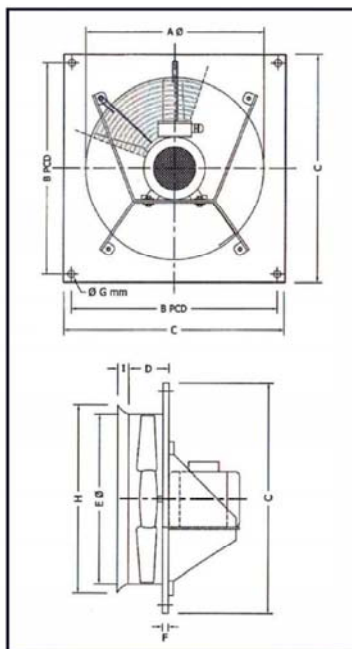

MODEL	A	B	C	D	E	F	G	H	I
315	315	390	430	100	315	12	9	360	20
355	355	420	460	100	355	12	9	405	25
400	400	480	510	120	400	12	10	450	25
450	450	510	550	120	450	12	10	495	25
500	500	590	630	120	500	12	14	550	25
560	560	630	670	120	560	15	14	615	30
630	630	710	750	120	630	15	14	685	30
710	710	800	840	120	710	15	14	750	30
800	800	900	950	120	800	15	14	840	30
900	900	970	1020	150	900	20	14	955	30
1000	1000	1070	1150	180	1000	25	14	1050	30
1120	1120	1190	1240	180	1120	30	16	1170	30
1250	1250	1320	1240	180	1250	30	16	1300	30

# WALL MOUNTED AXIAL PROPELLER

## PERFORMANCE CURVES

